

## DE Plan 600 Invisible Speaker

DEplan®

### Description

The DE Plan 600® is a high-end flat transducer which, once installed, remains completely invisible in walls or ceilings. The patented design concept of the DE Plan series means the large flat membrane is homogeneously deflected in the low frequency range. This produces an excellent low frequency sound with a low cut-off frequency.

de:shape®: the membrane of the DE Plan 600 has an optimized contour with a calculated distribution of distance between the edge and the high frequency driver (patent pending). This results in unprecedented audio performance and extremely accurate sound reproduction.

Sophisticated crossover tuning means the DE Plan 600 2-way system delivers clear music and speech reproduction. Additional subwoofers are not required. The DE Plan 600 is mainly intended as a front speaker in home audio systems or media rooms.

The DE Plan 600 is mounted facing outwards in hollow non-concrete walls and ceilings. It can also be installed in solid walls and concrete ceilings using an EGB Plan 600 back box. First, the speaker is mounted, then the glass fiber lining included with the package is placed around the membrane and the area can then be plastered and painted.

### Key Features

- Invisible flat transducer
- 180° dispersion
- Very linear frequency response
- Excellent low frequency sound
- 4 × 4" woofers + 1" high frequency driver
- 320 watts power capacity

### Fields of Application

- Gastronomy, hotels
- Home audio
- Shops, sales rooms
- Multiroom systems
- Surround systems

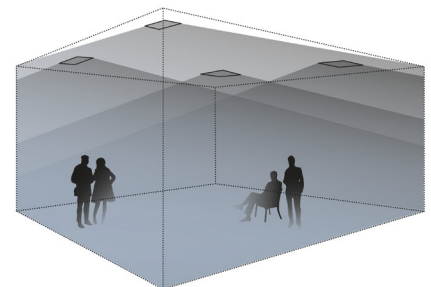

Dispersion Characteristic  
DE Plan 600 Speaker  
(In-Ceiling Installation)

# DE Plan 600 Invisible Speaker

## Dimensions

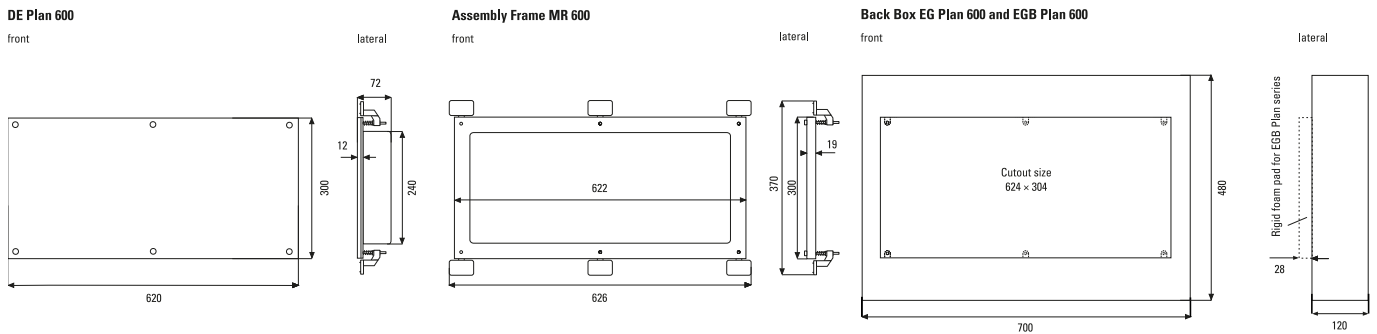

## Technical Data

Principle	2-way flat transducer
Components	4 × 4" woofers + 1" high frequency driver
Frequency range	42 Hz – 20 kHz (2 × paint-coated)
Impedance	8 ohms
Power capacity	160 watts RMS, 320 watts program
Sensitivity	83 dB (1 W@1 m), half-space (flush-mounted)
Maximum SPL	108 dB @ 1 m
Nominal dispersion (H × V)	180°
Dimensions	620 × 300 × 72 mm incl. mounting feet: 626 × 370 mm
Cutout size	624 × 304 mm
Wall / ceiling thickness	10 – 35 mm (incl. back box)
Installation depth	72 mm
Weight	5.5 kg
Connectors	Screw-type terminals, pluggable
Warranty	5 years

## Model

DE Plan 600

## Version

Complete incl. assembly frame, glass fiber fabric and adhesive

## Accessories

EG Plan 600



Back box  
Dim.: 700 × 480 × 120 mm

EGB Plan 600

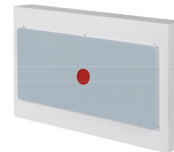

Back box for concrete  
Dim.: 700 × 480 × 120 mm

## Spare parts

MR 600



Assembly frame

## DE Plan 600 Invisible Speaker

### Measuring Diagram

DE Plan 600 Sens. @ 2, 83V/1m

